

ISOGOMMA



Manuale di posa

Installation manual



Il presente manuale di posa vuole rappresentare uno strumento in grado di spiegare e guidare nelle fasi di realizzazione dell'opera in cantiere. La posa corretta di tali prodotti è importantissima al fine di evitare banali errori, che in genere compromettono una corretta progettazione e di raggiungere le prestazioni acustiche qualitative richieste dai committenti e dalle normative vigenti. L'impegno nel comunicare queste informazioni agli addetti alla posa, è indispensabile per ottenere i risultati di progetto.

This manual has the scope to facilitate the Isolgomma products application in the construction site. In fact the correct product application is extremely important in order to get the insulation performance required in the project or by law. Therefore if the following working instructions and suggestions are followed, during the application of Isolgomma Products, the best products performance can be obtained.

INDICE

INDEX



Isolamento solai

Floor insulation

Massetto Flottante - <i>Floating screed</i>	<i>Upgrei - Grei - Roll - Rewall 28R - Syl</i>	3
Mas. Flot. Highmat - <i>Floating screed HighMat</i>	<i>Highmat</i>	8
Sottoceramica - <i>Underceramic</i>	<i>Sylcer</i>	12
Sottoparquet - <i>Underparquet</i>	<i>Sylwood</i>	16



Isolamento pareti

Wall insulation

Parete doppia - <i>Double wall</i>	<i>Biwall - Mustwall - Fybro</i>	20
Parete leggera - <i>Plasterboard wall</i>	<i>Trywall - Fybro</i>	25
Parete rivestita - <i>Coated wall</i>	<i>Rewall 40 - Rewall 33B - Mustwall 18/23/33B</i>	29



Isolamento soffitti

Ceiling insulation

Controsoffitto in aderenza - <i>Coated ceiling</i>	<i>Rewall 40 - Rewall 33B - Mustwall 18/23/33B</i>	32
Controsoffitto sospeso - <i>Suspended ceiling</i>	<i>Trywall - Biwall - Fybro</i>	35



Isolamento facciate

Facade insulation

Foro di ventilazione - <i>Ventilation hole</i>	<i>Sylencer</i>	39
--	-----------------	----



Isolamento strutturale

Structural insulation

Sottoparete - <i>Underwall</i>	<i>Stywall AD</i>	40
Fondazioni superficiali - <i>Structural bearings</i>	<i>Megamat</i>	41
Fondazione platea - <i>Ground slab foundation</i>	<i>Megamat</i>	42



Isolamento impianti

Systems insulation

Unità trattamento aria - <i>HVAC</i>	<i>Megamat</i>	44
Tubazioni - <i>Pipes</i>	<i>Stywall SA</i>	52

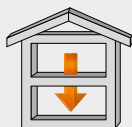

MASSETTO FLOTTANTE FLOATING SCREED

Uppgrei - Grei - Roll - Rewall 28R - Syl

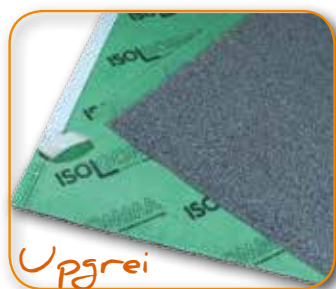
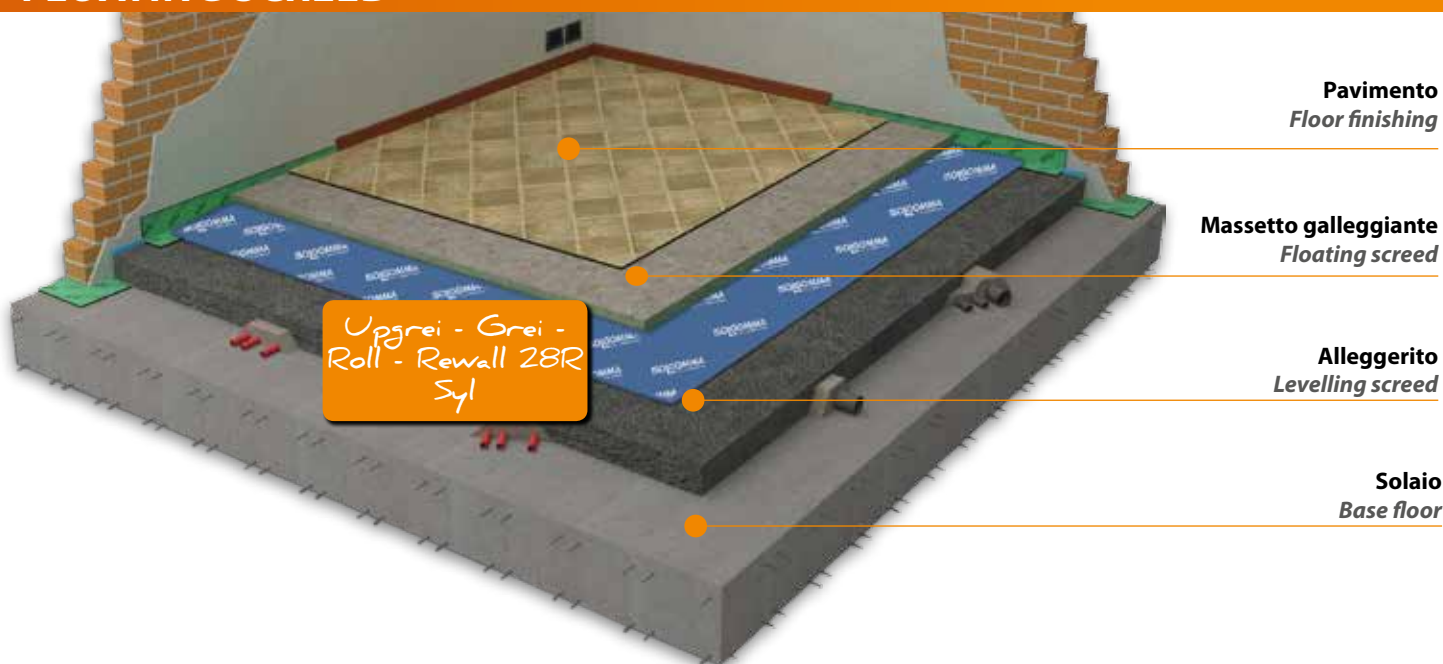

Uppgrei



Grei



Roll



Rewall 28R

Utilizzare la versione PTB con massetti liquidi
Use PTB version for liquid screed



Syl

Applicare un film protettivo prima del getto del massetto
Apply a protective film before casting the screed

Accessori - Accessories



Profyle



Stik



Profyle Flat 1

MASSETTO FLOTTANTE FLOATING SCREED



AVVERTENZE: WARNINGS:

- Non utilizzare direttamente sotto la pavimentazione di finitura
Don't use directly under the floor finishing
- Per lo spessore e l'eventuale armatura del massetto seguire le indicazioni in tabella
For recommended thickness and reinforcement of the screed, refer to the following table

Spessore dello strato isolante <i>Thickness of insulation layer</i>	Spessore del massetto tradizionale <i>Thickness of the floating screed without mesh</i>	Spessore del massetto armato <i>Thickness of the floating screed with mesh</i>
Fino a 5 mm / <i>Up to 5 mm</i>	≥ 5 cm	≥ 5 cm
Tra 5 e 10 mm / <i>From 5 to 10 mm</i>	≥ 6 cm	≥ 5 cm
Tra 10 e 30 mm / <i>From 10 to 30 mm</i>	≥ 7 cm	≥ 6 cm

- Il solaio deve essere ben costruito, privo di fori passanti e scassi
The floor must be built without holes and cracks
- il sottofondo alleggerito deve avere uno spessore minimo ≥ 5 cm e una densità ≥ 400 kg/m³
The light levelling screed must have a minimum thickness ≥ 5 cm and a density ≥ 400 kg / m³
- Fascia perimetrale: l'adesivo è molto efficace e potrebbe lasciare alcuni residui attaccati alla parete, dopo aver rimosso la parte in eccedenza alla quota della finitura. Nel caso in cui non sia previsto battiscopa, controllare che la fascia adesivizzata non superi la quota pavimento. Per rimuovere eventuali residui di adesivo, utilizzare un diluente nitro.
Edging Strip: the adhesive is very effective and may leave some residue on the walls, after removing the strip in excess at the flooring level. In the case the final floor will be left without skirting, be sure that the adhesive band is not exceeding the flooring quote. To remove any adhesive residue, use a nitro solvent.

PREPARAZIONE DELLA SUPERFICIE DI POSA / PREPARATION OF THE SUBSTRATE

Il supporto di posa deve essere planare e privo di fessure e asperità. Nel caso di utilizzo di calcestruzzi alleggeriti considerare la loro resistenza a compressione (≥ 10 kg/cm²) per evitare possibili cedimenti del sistema galleggiante.

The substrate must be mechanically strong, coherent, dry, flat, without cracks and free of dust. In case of use of light concrete consider a compressive strength ≥ 10 kg/cm² to prevent possible sinking of the floating system.

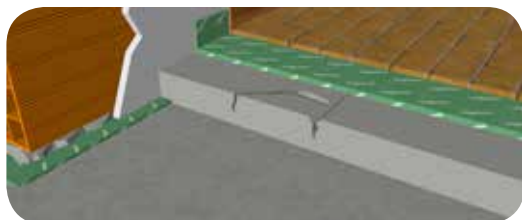

- ✓ Fessure: vanno riparate con opportuni prodotti, quali adesivi o resine epossidiche dedicate

Cracks: should be repaired with appropriate products, such as dedicated epoxy adhesive or resin

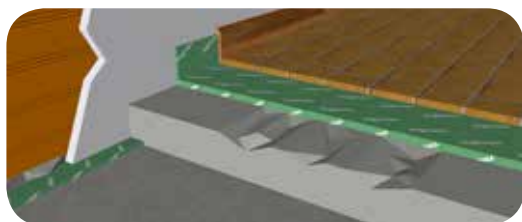

- ✓ Irregolarità della superficie: se la superficie non risulta planare e presenta asperità, deve essere opportunamente livellata

Irregularities of the surface: if the surface is not flat and it has irregularities, it must be properly leveled

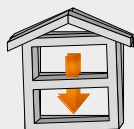

Upgrei - Grei - Roll - Rewall 28R - Syl

Realizzare il sottofondo con calcestruzzo alleggerito a contenimento degli impianti

Build the substrate with lightweight concrete to cover the pipes systems

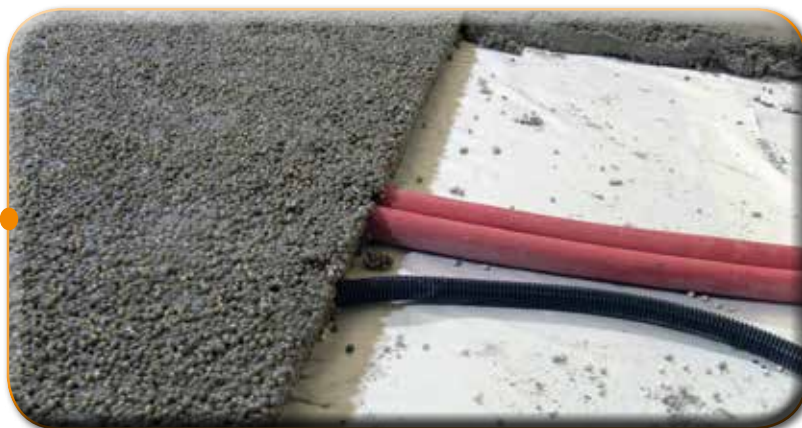

Pulire l'alleggerito da eventuali residui. Incollare la striscia perimetrale **Profyle** alla parete e al solaio rimuovendo la pellicola adesiva, realizzando gli angoli con cura

*Clean the surface area of installation of any residue. Apply the **Profyle** edging strip all along the perimeter of the room, caring to fix the strip both to the wall and the floor*

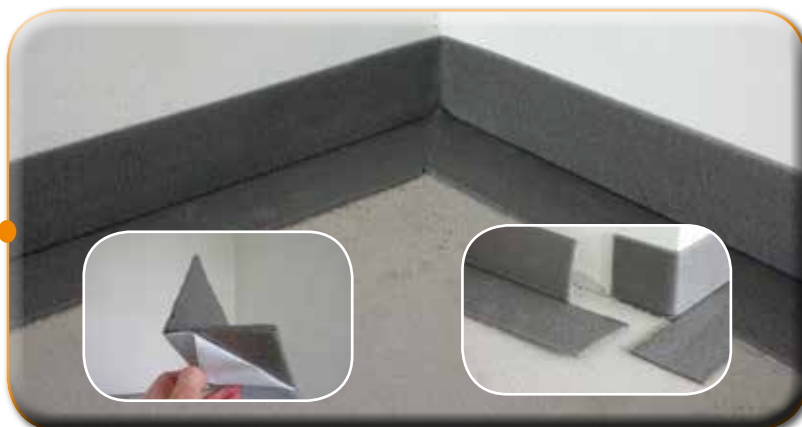

Stendere l'isolante acustico con i granuli di gomma rivolti verso il basso

Lay down the insulation layer on the floor surface with the rubber granules faced down



Incollare la cimosa adesiva aiutandosi con le linee di sormonto

Seal the overlapping band with the adhesive band on the roll edge. To do it properly follow the dotted end continues lines indication



MASSETTO FLOTTANTE FLOATING SCREED

In mancanza della cimosa adesiva, sigillare le giunzioni con apposito nastro **Stik**. Verificare che il materassino sia posato correttamente e privo di strappi

*In the absence of the adhesive flap, seal the joints with **Stik** tape. Always check that the mat is installed correctly and without tears*

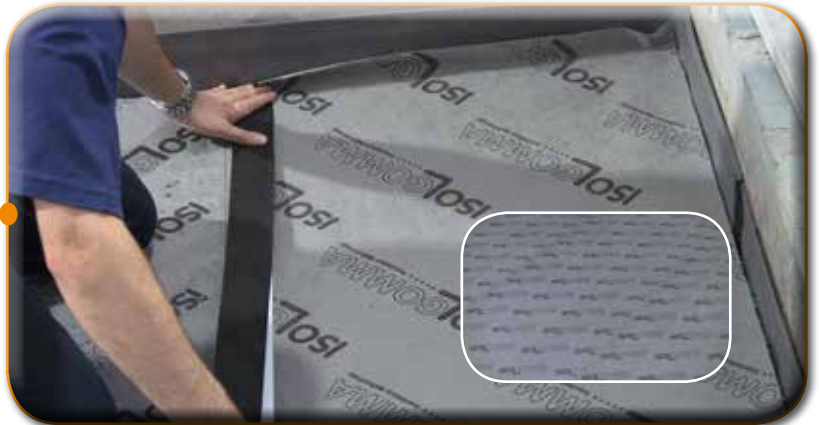

Nel caso di riscaldamento a pavimento posare il pannello radiante sopra al materassino

In the case of heating system lay down the heating panel above the acoustic insulation layer



Realizzare il massetto facendo riferimento alla tabella degli spessori (pag.4)

Cast the screed, (refer to the table at pag.4 for slab thickness)



Stendere lo strato di colla e posare le piastrelle. Successivamente eseguire la fugatura e pulire la superficie delle piastrelle

Lay the tiles on the adhesive, as desired. Apply the grouting glue and clean the ceramic tiles



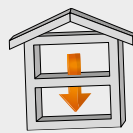

Upprei - Grei - Roll - Rewall 28R - Syl

Tagliare la striscia perimetrale **Profyle** e rimuovere la parte eccedente a livello della pavimentazione

*Cut the exceeding part of the **Profyle** edging strips, only when the floor finishing has been completely built*



Incollare il **Profyle Flat 1** al pavimento lungo il perimetro della stanza

*Apply the **Profyle Flat 1** on the floor finishing along the room's perimeter*



Posare il battiscopa sopra il **Profyle Flat 1**

*Install the skirting on the **Profyle Flat 1***



Quantità di Accessori - Accessories quantities

PROFYLE

1.2 m per ogni m²
di superficie di pavimento

1.2 m per m² of floor surface

STIK

0.1 m per ogni m²
di superficie di pavimento

0.1 m per m² of floor surface

PROFYLE FLAT 1

1.2 m per ogni m²
di superficie di pavimento

1.2 m per m² of floor surface

MASSETTO FLOTTANTE - LINEA HIGHMAT FLOATING SCREED - HIGHMAT LINE



Pavimento ceramica
Ceramic tiles flooring

Massetto galleggiante
Floating screed

Alleggerito
Levelling screed

Solaio
Base floor



Side Highmat

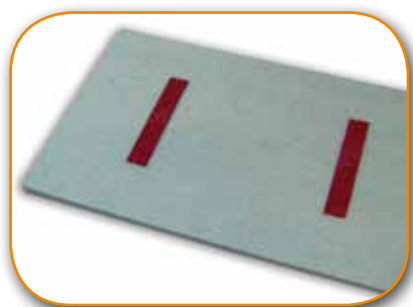

Highmat

DESCRIZIONE PRODOTTO / PRODUCT DESCRIPTION

Highmat è composto da un pannello in fibra di poliestere che presenta all'interno degli inserti in granuli di gomma SBR ed EPDM di densità kg 500/m³ a creare uno strato resiliente compatto e bi-fase su cui installare il massetto flottante.

The Highmat is made polyester fiber panel with in-built rubber bearings, assembled together as a composite and compact resilient sub-layer for floating screed applications.

Dimensioni Highmat:

- Pannello: 100 cm x 60 cm
- Spessore: 20 mm / 30 mm

Dimensioni Side Highmat:

100 cm x 5 cm

Highmat Dimensions

- Panel: 100 cm x 60 cm
- Thickness: 20 mm / 30 mm

Side Highmat Dimensions:

100 cm x 5 cm

Accessori - Accessories



Profyle Flat 5-15

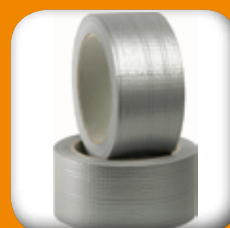

Stik



Profyle Flat 1

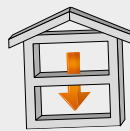

Highmat



INDICAZIONI SULLA DISPOSIZIONE DEI COMPONENTI *INDICATIONS FOR THE COMPOSITION OF THE SYSTEM*

- Preparare il piano di posa come indicato a pag. 4. Dopo aver installato Profyle Flat e Side Highmat lungo il perimetro, partire con un pannello Highmat intero nella prima fila e con mezzo pannello nella seconda fila. Procedere con la posa, in modo che gli appoggi in gomma risultino allineati tra file attigue [1]. L'orientamento delle file è a discrezione dell'installatore [2][3]

Prepare the substrate according to the indications at page 4. After installing Profyle Flat and Side Highmat along the perimeter of the room, start with one whole Highmat panel in the first row and with half panel in the second row. Continue the installation, so that the rubber bearings appear aligned among the different rows [1]. The installation team can choose the rows orientation [2][3]

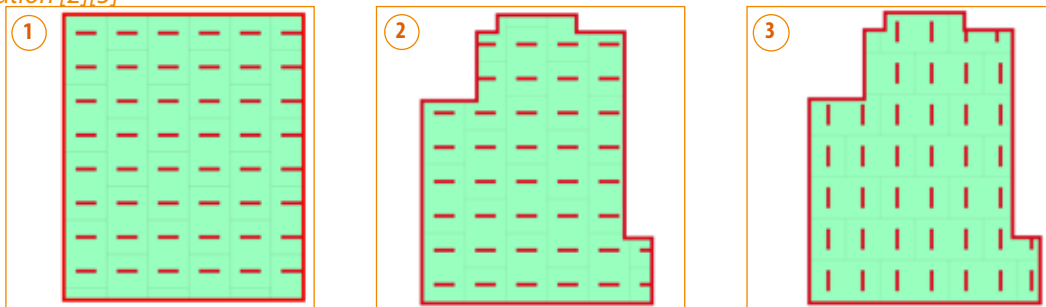

- Al termine della fila, dove si rende necessario un taglio del pannello Highmat, riempire lo spazio rimanente prelevando il materiale da un nuovo pannello. Lo scarto può essere utilizzato nei successivi fine linea oppure può essere ridotto a metà pannello per cominciare una nuova fila. Inoltre si possono riutilizzare porzioni di pannelli, per formare nuovi componenti, giuntando le parti mediante nastro Stik. Il sistema Highmat è stato studiato per poter recuperare il più possibile gli sfridi di installazione [4] [5]

In the case where a Highmat panel has to be cut at the end of a row, a portion of product can be taken from a new panel. The remaining part of the panel can be used at the end of the following rows, or it can be reduced to half panel to begin a new row. Portions of panels obtained from cut can be reused and assembled together with the Stik tape. The Highmat system has been developed taking into account the possibility to recover most of the cut pieces [4] [5]

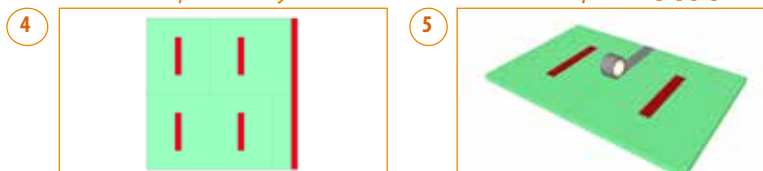

- Il massetto di sabbia e cemento o autolivellante deve avere uno spessore superiore a 6 cm e densità almeno 2000 kg/m³ e deve essere inoltre necessariamente rinforzato mediante rete di armatura di diametro 5 mm e maglia 200 mm posizionata ad un'altezza di circa 20 mm dal piano del materassino resiliente. Per spessori di massetto superiore ai 100 mm, prevedere una pannellatura in legno come cassero a perdere (spessore almeno 15 mm) [6]. Prima del getto proteggere la superficie mediante telo impermeabile

The screed, made in sand and cement or self-levelling, should have a thickness higher than 6 cm and a minimum density of 2000 kg/m³ and must be reinforced with a steel mesh (steel rod diameter 5 mm, spaced 200 mm), positioned at a height of approximately 20 mm from the upper surface of the resilient layer. For screed thicknesses higher than 100 mm, an additional wooden permanent framework should be installed (minimum thickness 15 mm) [6]. Before casting the screed, protect the product surface with a waterproof foil

- Durante il getto del massetto il prodotto Highmat può subire una parziale deflessione in corrispondenza alla parte del pannello in fibra di poliestere: si consiglia di prevedere un quantitativo superiore di materiale cementizio, dell'ordine di 1 cm in aggiunta allo spessore nominale [7]

During the screed construction, the Highmat product undergoes a partial deflection, especially in the part of the panel made of polyester fiber: during the designing phase of the screed, it is suggested to consider screed materials in excess up to 1 cm in addition to the nominal thickness of the screed



MASSETTO FLOTTANTE - LINEA HIGHMAT FLOATING SCREED - HIGHMAT LINE

Pulire l'alleggerito da eventuali residui. Incollare la striscia perimetrale **Profyle Flat** alla parete senza ripiegarla alla base del solaio, rimuovendo la pellicola adesiva e realizzando gli angoli con cura

*Clean the surface of installation of any residue. Apply the edging strip **Profyle Flat** on the perimeter vertically, without folding on the base floor and with particular care in the corners*



Posare le strisce **Side Highmat** su tutto il perimetro a ridosso della fascia **Profyle**, creando una superficie d'appoggio lineare continua. Dove necessario, ritagliare con precisione gli appoggi mediante un comune cutter

*Place the **Side Highmat** bearings along the whole perimeter next to the **Profyle**, making a continuous linear bearing surface. Where necessary, cut the bearings up to the desired length with a common cutter*



Posare i pannelli **Highmat** in file contigue. Per una corretta disposizione seguire istruzioni dettagliate a pag.9. I pannelli possono essere portati a misura tagliandoli con cutter

*Place the **Highmat** panels in adjacent rows. For a correct disposition see detailed instructions at page 9. The panels can be cut using a common cutter*



Sigillare eventuali fessure (>2mm) tra i componenti mediante il nastro **Stik**. I pannelli **Highmat** sono prodotti con tolleranze dimensionali strette; tuttavia possono comparire fessure in caso di irregolarità geometriche degli ambienti di posa od in seguito al taglio manuale

*Seal any gap (> 2 mm) between two adjacent components with **Stik** tape. **Highmat** panels are produced with strict tolerances, however gaps can appear in case of dimensional irregularities of the installation area or after cutting the panels manually*





Highmat

Applicare uno telo protettivo di adeguata resistenza meccanica prima della realizzazione del massetto. Coprire con precisione tutta la superficie del materassino, sigillando il telo ai bordi e nelle giunzioni mediante nastro **Stik**

*Place a protection film with sufficient mechanical strength (for example a PE or Nylon film), before building the screed. Cover the whole mat surface accurately, sealing the film to the edges and at the joints with **Stik** tape*



Gettare il massetto in sabbia e cemento o autolivellante, rinforzato con rete d'armatura. L'altezza totale del massetto va misurata dalla superficie superiore dell'insero in gomma

Build the screed (sand and cement or self-levelling) with a reinforcement mesh. The total height of the screed should be measured starting from the top of the rubber bearings



Installare la pavimentazione, quindi tagliare la striscia perimetrale e rimuovere la parte eccedente a livello della pavimentazione. Incollare **Profyle Flat 1** al pavimento ed installare il battiscopa sopra il Profyle Flat 1

*Install the floor finish then cut the exceeding part of the edging strips at the flooring finish level. Apply the **Profyle Flat 1** on the floor and install the skirting board on top of Profyle Flat 1*



Quantità di Accessori - Accessories quantities

PROFYLE FLAT 5-15 - SIDE HIGHMAT

0.8 - 1.2 m per ogni m²
di superficie di pavimento

0,8 - 1.2 m per m² of floor surface

STIK

0.8 - 1.2 m per ogni m²
di superficie di pavimento

0,8 - 1.2 m per m² of floor surface

PROFYLE FLAT 1

1.2 m per ogni m²
di superficie di pavimento

1.2 m per m² of floor surface

SOTTOCERAMICA UNDERCERAMIC



Pavimento ceramica
Ceramic tile floor

Pavimentazione esistente
Existing floor

Alleggerito
Leveling screed

Solaio
Base floor

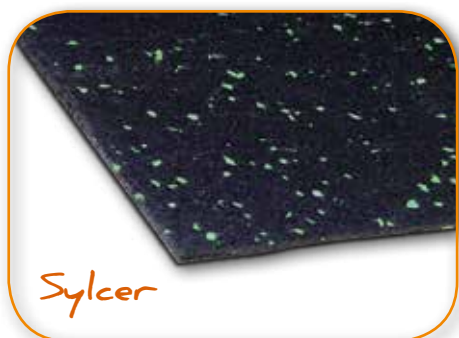

Sylcer

**Utilizzabile su massetto o su
pavimentazioni esistenti**
*Can be used on the screed or existing
flooring surface*

Accessori - Accessories



1 Profyle Flat 5



2 Stik



Profyle Flat 1



3A Ultrabond
Eco V4 SP



3B Ultrabond
Eco S955 1K



4 Elastorapid A+B



5 Ultracolor Plus

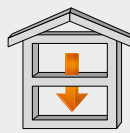

Sylcer



AVVERTENZE:
WARNINGS:

- Utilizzare solo in ambienti interni, non sottoporre a carichi pesanti
Apply only indoor don't apply in areas subject to heavy traffic
- Utilizzare solo su superfici orizzontali, in interno e su supporti solidi
Apply only on horizontal surfaces, indoor and on solid substrate
- Non utilizzare sotto pavimentazioni resilienti leggere, lucide o in cushion
Don't apply under lightweight or shiny resilient floor coverings or under cushion floor
- Applicare su supporto cementizio solo dopo la sua completa stagionatura
When applying the product to cementitious substrates ensure they are completely cured
- Non utilizzare su sottofondi soggetti a umidità continua
Don't apply on substrates subject to continuous rising moisture
- Fascia perimetrale: l'adesivo è molto efficace e potrebbe lasciare alcuni residui attaccati alla parete, dopo aver rimosso la parte in eccedenza alla quota della finitura. Nel caso in cui non sia previsto battiscopa, controllare che la fascia adesivizzata non superi la quota pavimento. Per rimuovere eventuali residui di adesivo, utilizzare un diluente nitro.
Edging Strip: the adhesive is very effective and may leave some residue on the walls, after removing the strip in excess at the flooring level. In the case the final floor will be left without skirting, be sure that the adhesive band is not exceeding the flooring quote. To remove any adhesive residue, use a nitro solvent.

PREPARAZIONE DELLA SUPERFICIE DI POSA / *PREPARATION OF THE SUBSTRATE*

Sylcer può essere posato su tutti i supporti a base cementizia e su pavimentazioni esistenti; le superfici devono essere stagionate, consistenti, asciutte, planari, senza fessurazioni e pulite.

Sylcer can be laid on all type of cementitious substrate and on existing floor finishing; the substrate must be mechanically strong, coherent, dry, flat, without cracks and free of dust.

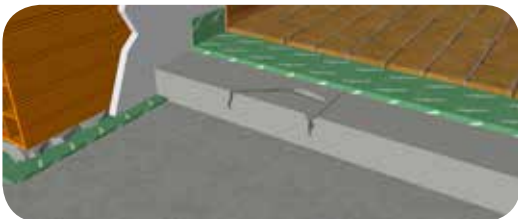

- ✓ Fessure: vanno riparate con opportuni prodotti, quali adesivi o resine epossidiche dedicate

Cracks: should be repaired with appropriate products, such as dedicated epoxy adhesive or resin

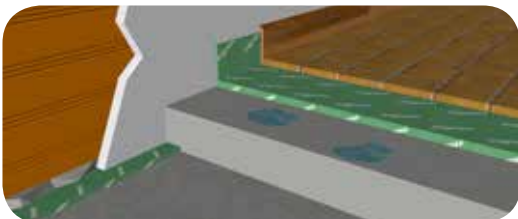

- ✓ Umidità: nel caso di eccessiva umidità del supporto trattare la superficie con un primer impermeabilizzante

Moisture: if the moisture content is too high, apply a waterproofing primer

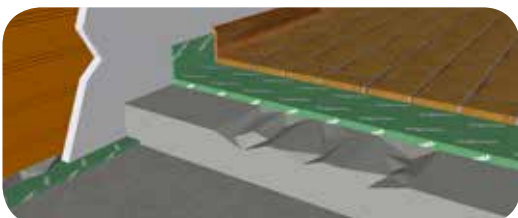

- ✓ Irregolarità della superficie: se la superficie non risulta planare e presenta asperità, deve essere opportunamente livellata

Irregularities of the surface: if the surface is not flat and regular, it must be properly leveled

SOTTOCERAMICA UNDERCERAMIC

Posare il **Profyle Flat 5** lungo il perimetro della stanza. Successivamente preparare il Sylcer tagliato su misura

*Fix the **Profyle Flat 5** along the perimeter of the room and then prepare the Sylcer cut to size of the laying surface*



Posare un sottile strato di colla (scelta in funzione del supporto pag. 11) e stendere il **Sylcer**. Massaggiare la superficie con un rullo rigido o con una spatola per migliorare l'aderenza

*Spread a thin layer of adhesive onto the floor, then glue the **Sylcer** (pg.11). Massage the surface with a rigid roller or flat trowel to improve adhesion*



Nastrare con il nastro **Stik** le giunzioni dei rotoli

*Tape all the Sylcer jointing borders with the **Stik** tape*



A distanza di 24/48 ore posare lo strato di colla **Mapei Elastorapid** e disporre le piastrelle a piacimento

*After 24/48 hours of dry time, apply the **Mapei Elastorapid** glue as shown in the pictures and then install the ceramic tiles*



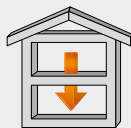

Sylcer

Eseguire la fugatura delle piastrelle con **Mapei Ultracolor Plus** e ad inizio indurimento della fuga pulire la superficie delle piastrelle

*Apply the grouting glue **Mapei Ultracolor Plus**. When the grouting is solidify, clean the ceramic*



Tagliare la striscia perimetrale **Profyle Flat 5** e rimuovere la parte eccedente a livello della pavimentazione

*When the ceramic floor is completed, cut the exceeding part of the **Profyle Flat 5** edging strips*



Applicare il **Profyle Flat 1** e posare il battiscopa

*Apply the **Profyle Flat 1** on the floor finishing and install the skirting on the Profyle Flat 1*



Quantità di Accessori - Accessories quantities

Incollaggio Sylcer
(Supporto assorbente -
Massetto)
Bonding Sylcer
(absorbing surface -
Floating Screed)

Incollaggio Sylcer
(Supporto non assorbente -
pavimento)
Bonding Sylcer
(non-absorbing surface -
Flooring)

Posa piastrelle
(formato standard)
Glue ceramic tiles
(standard dimensions)

Fugatura piastrelle
Ceramic finishing

Desolarizzazione
pavimento
Side protection

Nastratura
Taping

MAPEI Ultrabond
Eco V4 SP

0,25 ÷ 0,40 kg/m²

MAPEI Ultrabond
Eco S955 1K

0,80 ÷ 1,20 kg/m²

MAPEI
Elastorapid

3,00 ÷ 8,00 Kg/m²

MAPEI
Ultracolor Plus

0,20 ÷ 2,40 kg/m²

PROFYLE FLAT 5

1.2 m per ogni m²
di superficie di pavimento
1.2 m per sqm floor surface

STIK

0.1 m per ogni m²
di superficie di pavimento
0.1 m per sqm floor surface

I collanti suggeriti possono essere sostituiti con prodotti aventi le stesse caratteristiche chimico-fisiche.
The suggested adhesive can be replaced with a product having the same chemical-physical characteristics.

**SOTTOPARQUET
UNDERPARQUET**



Pavimento in legno
Wooden floor

Pavimentazione esistente
Existing floor

Cappa collaborante
Base screed

Solaio in legno
Wooden floor



**Utilizzabile su massetto o su
pavimentazioni esistenti**
*Can be used on the screed or existing
floor finishing*

Accessori - Accessories



1 Profyle Flat 5

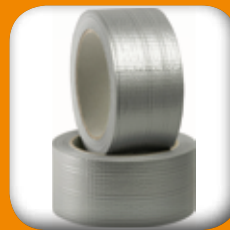

2 Stik



Profyle Flat 1



3A Ultrabond
Eco V4 SP



4 Ultrabond
Eco S955 1K

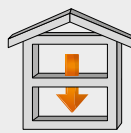

Sylwood



AVVERTENZE: WARNINGS:

- Utilizzare solo in ambienti interni, non sottoporre a carichi pesanti
Apply only indoor don't apply in areas subject to heavy traffic
- Utilizzare solo su superfici orizzontali, in interno e su supporti solidi
Only apply in horizontal surfaces indoor and on solid substrate
- Non utilizzare sotto pavimentazioni resilienti leggere, lucide o in cushion
Don't apply under lightweight or shiny resilient floor coverings or under cushion floor
- Applicare su supporto cementizio solo dopo la sua completa stagionatura
When applying the product to cementitious substrates ensure they are completely cured
- Non utilizzare su sottofondi soggetti a umidità continua
Don't apply on substrates subject to continuous rising moisture
- **Fascia perimetrale:** l'adesivo è molto efficace e potrebbe lasciare alcuni residui attaccati alla parete, dopo aver rimosso la parte in eccedenza alla quota della finitura. Nel caso in cui non sia previsto battiscopa, controllare che la fascia adesivizzata non superi la quota pavimento. Per rimuovere eventuali residui di adesivo, utilizzare un diluente nitro
Edging Strip: *the adhesive is very effective and may leave some residue on the walls, after removing the strip in excess at the flooring level. In the case the final floor will be left without skirting, be sure that the adhesive band is not exceeding the flooring quote. To remove any adhesive residue, use a nitro solvent*

PREPARAZIONE DELLA SUPERFICIE DI POSA / PREPARATION OF THE SUBSTRATE

Sylwood può essere posato su tutti i supporti a base cementizia e su pavimentazioni esistenti; le superfici devono essere stagionate, consistenti, asciutte, planari, senza fessurazioni e pulite.

Sylwood can be laid on all type of cementitious substrate and on existing floor finishing; the substrate must be mechanically strong, coherent, dry, flat, without cracks and free of dust.

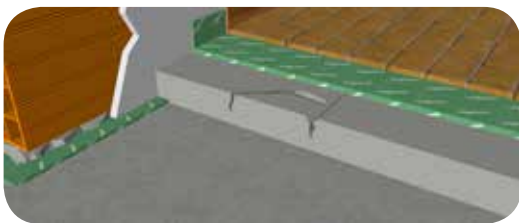

- ✓ Fessure: vanno riparate con opportuni prodotti, quali adesivi o resine epossidiche dedicate

Cracks: should be repaired with appropriate products, such as dedicated epoxy adhesive or resin

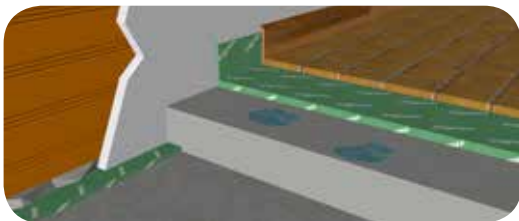

- ✓ Umidità: nel caso di eccessiva umidità del supporto trattare la superficie con un primer impermeabilizzante

Moisture: if the moisture content is too high, apply a waterproofing primer

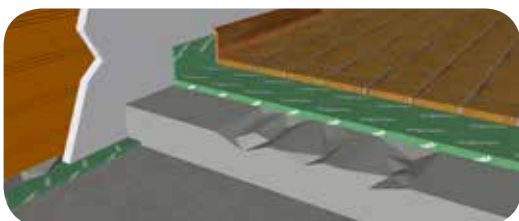

- ✓ Irregolarità della superficie: se la superficie non risulta planare e presenta asperità, deve essere opportunamente livellata

Irregularities of the surface: if the surface is not flat and regular, it must be properly leveled

SOTTOPARQUET UNDERPARQUET

Posare il **Profyle Flat 5** lungo il perimetro della stanza. Successivamente preparare il Sylwood tagliato su misura

*Fix the **Profyle Flat 5** along the perimeter of the room and then prepare the Sylwood cut to size of the laying surface*



POSA A COLLA - GLUE APPLICATION

Posare un sottile strato di colla (scelta in funzione del supporto pag. 16) e stendere il Sylwood. Massaggiare la superficie con una spatola migliorare l'aderenza

Apply the mat glue (pg. 16), then lay down the Sylwood rolls. Massage the surface with a rigid roller or flat trowel to improve adhesion



Nastrare con il nastro **Stik** le giunzioni dei rotoli

*Jointing the borders with the adhesive **Stik** tape*



A distanza di 24/48 ore posare lo strato di colla per parquet **Mapei Ultrabond Eco S955 1 K** e applicare le tavole

*Glue the parquet boards over the Sylwood mat with the **Mapei Ultrabond Eco S955 1 K** glue*



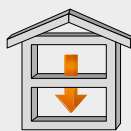

Sylwood

POSA A SECCO - DRY APPLICATION

Posare il **Sylwood**

*Lay down the **Sylwood***



Nastrare con lo **Stik** le giunzioni dei rotoli

*Seal the roll jointing borders with the adhesive **Stik** tape*



Posare a secco le tavole di parquet

Apply the floating parquet boards (without glue)



Rifilare **Profyle Flat 5**

*When the flooring is completed, cut the exceeding part of the **Profyle Flat 5** edging strips*



Applicare il **Profyle Flat 1**

*Apply the **Profyle Flat 1** on the floor finishing*



Applicare il battiscopa

Install the skirting



Quantità di Accessori - Accessories quantities

**Incollaggio Sylwood
(Supporto assorbente -
Massetto)**

*Bonding Sylwood
(absorbing surface -
Floating screed)*

**Incollaggio Sylwood
(Supporto non
assorbente)**

*Bonding Sylwood
(non-absorbing surface)*

**Incollaggio parquet
Gluing parquet**

**Desolarizzazione
pavimento
Side protection**

**Nastratura
Taping**

**MAPEI Ultrabond
Eco V4 SP**

0,25 ÷ 0,40 kg/m²

**MAPEI Ultrabond
Eco S955 1K**

0,80 ÷ 1,20 kg/m²

**MAPEI Ultrabond
Eco S955 1 K**

0,80 ÷ 1,20 Kg/m²

PROFYLE FLAT 5

1.2 m per ogni m²
di superficie di pavimento
1.2 m per sqm floor surface

STIK

0.1 m per ogni m²
di superficie di pavimento
0.1 m per sqm floor surface

I collanti suggeriti possono essere sostituiti con prodotti aventi le stesse caratteristiche chimico-fisiche.
The suggested adhesive can be replaced with a product having the same chemical-physical characteristics.



PARETE DOPPIA
DOUBLE WALL

Biwall - Mustwall - Fybro

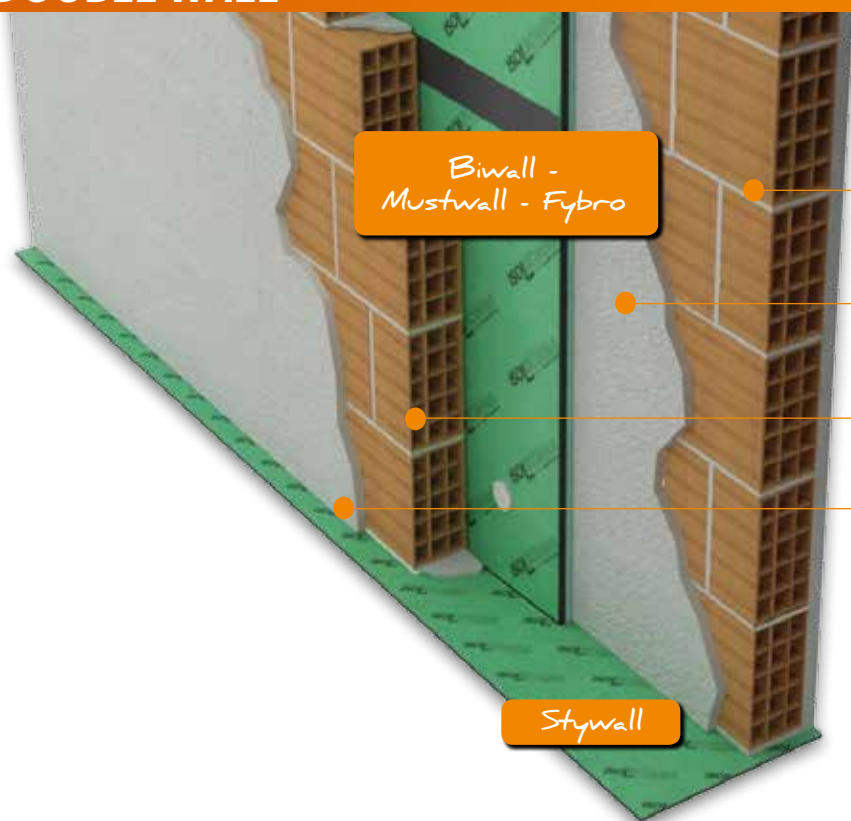

Laterizio
Brick wall

Rinzaffo
Raw plaster

Laterizio
Brick wall

Intonaco
Plaster

Stywall



Biwall



Mustwall

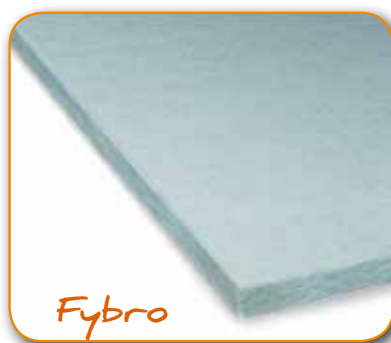

Fybro

Accessori - Accessories



Stywall



Stik



*Colla/Glue
Perlfix*

PARETE DOPPIA DOUBLE WALL



AVVERTENZE: WARNINGS:

- Procedura di posa con colla suggerita per Mustwall – Biwall
Laying instruction with glue suggest for Mustwall – Biwall
- Procedura di posa a secco suggerita per il Fybro
Dry laying instruction suggest for Fybro
- Le pareti devono essere ben costruite, prive di fori passanti e scassi
The walls must be built without holes and cracks
- I prodotti si possono tagliare con cutter, sega circolare, smerigliatrice con disco diamantato
The products can be cut with a cutter, circular saw, grinding machine with diamond blade

Stendere la striscia sottoparete. La striscia deve essere più larga della parete di almeno 2 cm per lato

Lay the under wall strip. The strip must be wider than the wall thicknees of at least 2 cm per side

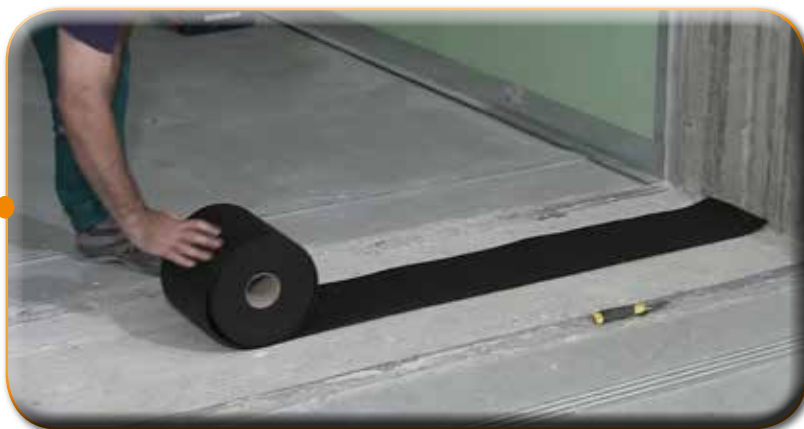

Realizzare la prima parete sopra la striscia sottoparete **Stywall** posandola su un letto di malta

*Build the first brick row on the **Stywall** stripe, with a mortar layer between bricks and rubber mat*



Completare la prima parete avendo cura di sigillare i giunti orizzontali e verticali fra i blocchi

Build the wall, caring to seal the blocks with mortar on both vertical and horizontal joints





Biwall - Mustwall - Fybro

Realizzare il rinzafo. Deve avere uno spessore di almeno 1 cm

Apply in the first wall a layer of row mortar of about 1 cm thickness



POSA A COLLA - GLUE APPLICATION

Stendere la colla a tasti sul pannello a terra (5 per pannello)

Apply the glue on the panel in dots (5 dots per panel)



Incollare il pannello alla parete facendo una leggera pressione

Apply the panel on the wall by forcing with homogeneous pressure



Sigillare le giunzioni tra i pannelli con l'apposito nastro **Stik**. **Successivamente realizzare la seconda parete**

*When all panels are fixed seal the panel joints with the **Stik** tape. Build the second wall*



POSA A SECCO - DRY APPLICATION

Realizzare la seconda parete inserendo in intercapedine il pannello isolante a secco

Build up the second wall and to install the acoustic panel into the cavity without glue



Realizzare la seconda parete avendo cura di sigillare i giunti orizzontali e verticali fra i blocchi

Build the second wall with the same process of the first one



Realizzare l'intonaco

Cover the wall with plaster



Quantità di Accessori - Accessories quantities

COLLA - GLUE

5 Kg/m² per pannello
5 Kg/m² per panel

STIK

1 m per ogni m²
di superficie di parete
1 m per m² of wall surface



PARETE LEGGERA
PLASTERBOARD WALL

Trywall - Fybro



Trywall -
Fybro

Stywall S3A

Cartongesso
Plasterboard

Struttura metallica
Metal frame

Cartongesso
Plasterboard

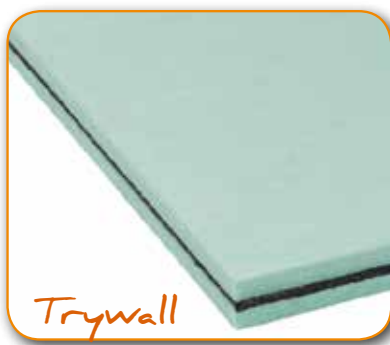

Trywall

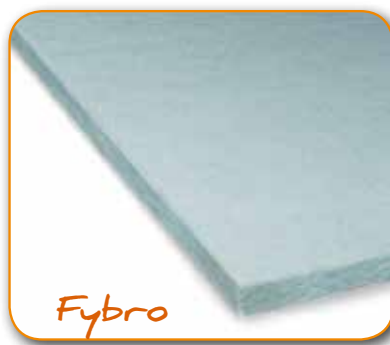

Fybro

Accessori - Accessories



Stywall S3A



Stik



Vite doppio filetto /
Double thread screw



Stucco da cartongesso &
nastro in rete /
Filling for plasterboard
& Mesh tape

PARETE LEGGERA PLASTERBOARD WALL

Incollare alle guide metalliche la striscia adesivizzata **Stywall S3A**

*Glue on the metal studs the type **Stywall S3A** adhesive strip*



Fissare le guide metalliche al solaio, alle pareti laterali e al soffitto

Fix the metal studs on the floor, walls and ceiling



Inserire i profili metallici e fissarli alle guide

Fix the vertical metal studs on the ceiling and bottom guides by screwing



Applicare le strisce adesive **Stywall S3A** sui profili per aumentare l'effetto isolante della parete

*Apply the adhesive **Stywall S3A** strips on the boards side of vertical metal studs*





Trywall - Fybro

Fissare le lastre di cartongesso da un lato

Fix the gypsum boards on one side



Inserire i pannelli tra un profilo e l'altro

Insert the panels in the metal frame



Completare l'inserimento del prodotto tra i profili

Complete the insulation application in the metal structure



Applicare le strisce adesive **Stywall S3A** sui profili per aumentare l'effetto isolante della parete

*Apply the adhesive **Stywall S3A** strips on the boards side of vertical metal studs*



Fissare le lastre in cartongesso sui profili metallici per chiudere la parete

Cover the insulation layer by screwing the second gypsum boards on the metal studs



Applicare il nastro in rete nelle giunzioni delle lastre. Stuccare le giunzioni

Apply the plastic mesh tape in the gypsum boards jointing lines and grouting



OPZIONI AGGIUNTIVE - *OPTIONS*

Realizzare la seconda struttura metallica per creare una parete doppia

Install the second metal studs structure



Per migliorare la parete fissare una seconda lastra di cartongesso al centro e ai lati con le apposite viti da cartongesso, sfalsando le lastre rispetto a quelle sottostanti

To improve structurally the dry wall apply a second gypsumboard layer. In this second layer, the boards should be installed with a half-board offset on the first layer





PARETE RIVESTITA
COATED WALL

Rewall - Mustwall

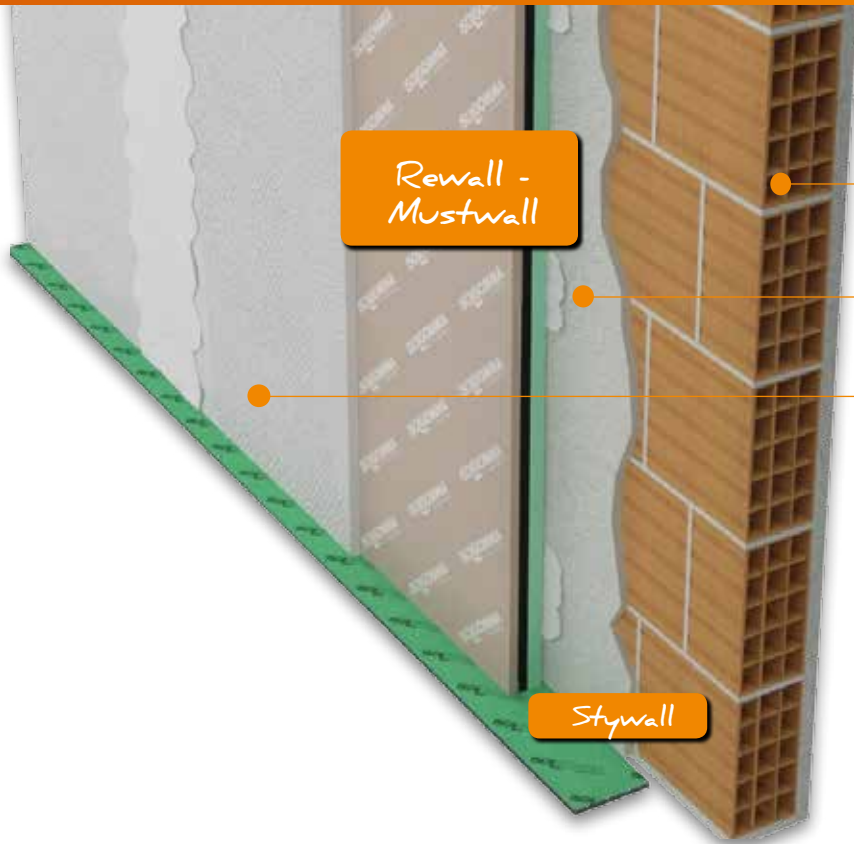

Laterizio
Brick wall

Intonaco
Plaster

Cartongesso
Plasterboard

Stywall

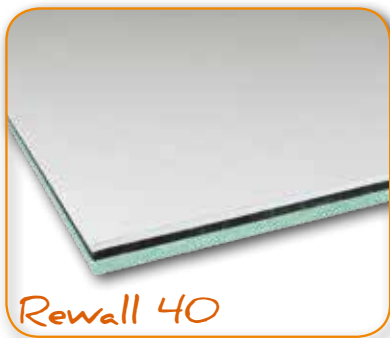

Rewall 40



Rewall 33B



Mustwall B

Accessori - Accessories



Stywall



Fissaggio Passante /
Long Fixing



Colla - Glue



Vite doppio filetto /
Double thread screw



Stucco da cartongesso &
nastro in rete /
Filling for plasterboard
& Mesh tape

PARETE RIVESTITA COATED WALL

Preparare la parete per la posa del pannello rimuovendo l'eventuale vernice. Posare la striscia sottoparete

Prepare the base wall for the installation removing any existing painting. Lay the under wall stripe



Stendere la colla **Knauf Perlfix** a tasti sul pannello a terra

*Apply the glue **Knauf Perlfix** in dots on the panel laid on the ground*

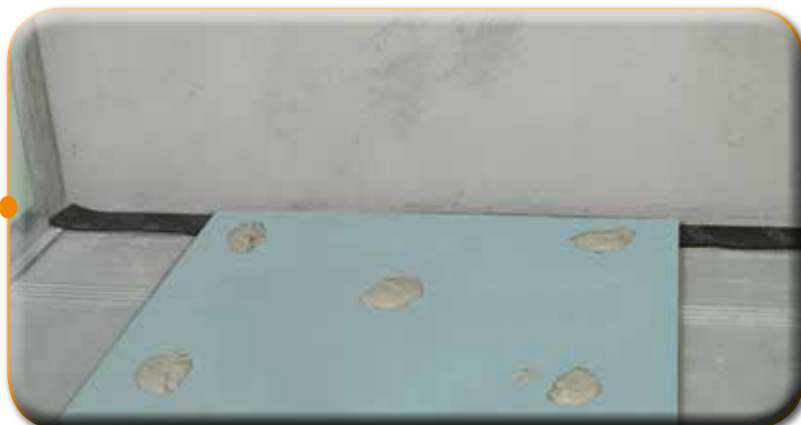

Incollare il pannello alla parete facendo una leggera pressione.

Apply the panel on the wall by forcing with homogeneous pressure.



Dopo circa 30 minuti forare il prodotto e la muratura sottostante in nr. 6 punti per ogni lastra e installare il **Fissaggio passante**

*After 30 minutes drill the product and the wall behind with 6 holes per panel and apply the **Long Fixing***





Rewall - Mustwall

A distanza di 2/3 ore fissare l'eventuale seconda lastra di cartongesso al centro e ai lati con le apposite viti "a doppio filetto", sfalsando le lastre rispetto a quelle sotto

After 2/3 hours, fix the second gypsum board by screwing it on centre line and on the side borders with double threads screws. Install the second boards with a half-board offset on the first layer



Applicare il nastro in rete nelle giunzioni delle lastre. Stuccare le giunzioni

Apply the plastic mesh tape in the gypsum boards jointing lines and grouting



Quantità di Accessori - Accessories quantities

COLLA - GLUE

5 Kg/m² per pannello
5 Kg/m² per panel

FISSAGGIO PASSANTE **LONG FIXING**

6 tasselli per pannello
6 rawl plug

CONTROSOFFITTO IN ADERENZA COATED CEILING

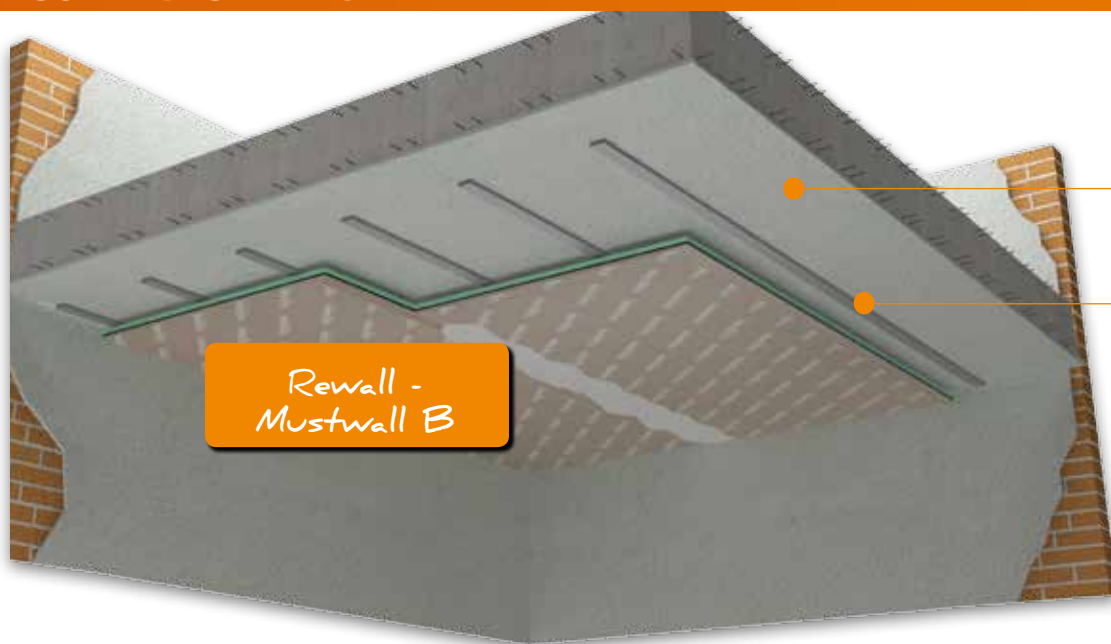

Solaio
Concrete base

Struttura metallica
Metal frame

Questo controsoffitto deve essere realizzato con struttura metallica e l'utilizzo del gancio a scatto o della staffa universale permette un ribassamento da 3 cm a 12 cm
This ceiling must be installed on a metal frame; by using the klik-on system or universal bracket it can be lowered from 3 to 12 cm



Accessori - Accessories

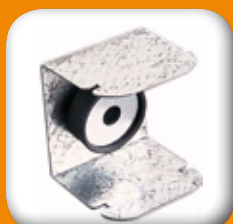

Gancio a scatto /
Clip-on system

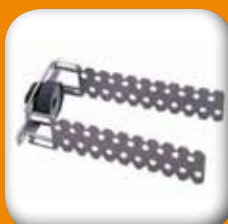

Staffa universale /
Universal bracket



Vite doppio filetto /
Double thread screw



Stucco da cartongesso &
nastro in rete /
Filling for plasterboard
& Mesh tape

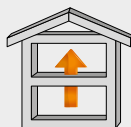

Rewall - Mustwall B

Incollare alle guide metalliche la striscia adesivizzata **Stywall S3A** e fissarle lungo il perimetro superiore della stanza

*Glue the adhesive strip **Stywall S3A** to the metal studs and fix them along the upper perimeter of the room*

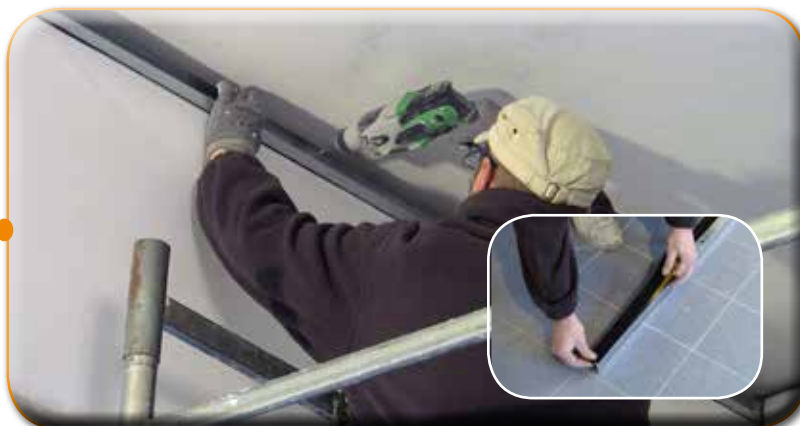

Prevedere un profilo ogni 40 cm da fissare con un gancio ogni 60 cm

Calculate the distance of the metal studs of 40 cm and fix the acoustic bracket every 60 cm



Forare il soffitto e fissare il gancio isolante

Drill the ceiling e fix the acoustic bracket



Fissare i profili metallici

Fix the metal stud to the acoustic bracket

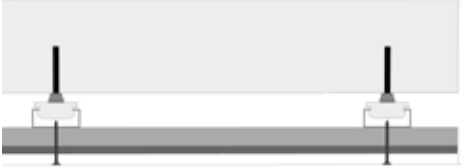

Carico P <i>Load P (kg/m²)</i>	Distanza ganci - A (mm) <i>Hangers distance</i>	Distanza profili portanti - B (mm) <i>Primary grid (metal studs) distance</i>
< 25	 <p>600</p>	 <p>400</p>

Appoggiare il pannello ai profili metallici e fissarlo con viti da 55 mm ogni 15 cm

Lean the panel to the metal frame and fix the panel to the metal frame with 55 mm screws every 15 cm



Riempire le eventuali giunture tra pannelli

Fill the possible gaps between panels



Applicare il nastro in rete nelle giunzioni delle lastre. Stuccare le giunzioni

Apply the plastic mesh tape in the gypsum boards jointing lines and grouting



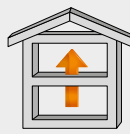

CONTROSOFFITTO SOSPESO
SUSPENDED CEILING

Trywall - Biwall - Fybro

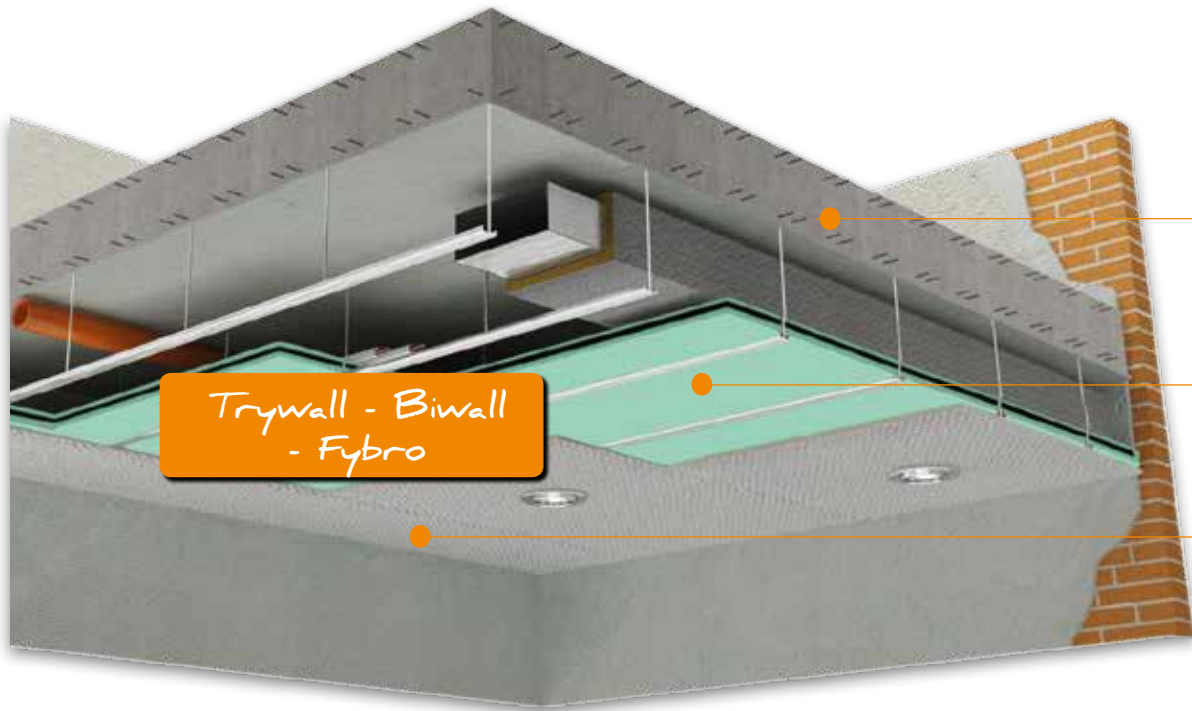

Trywall - Biwall
- Fybro

Solaio
Concrete base

Struttura metallica
Metal frame

Cartongesso
Plasterboard

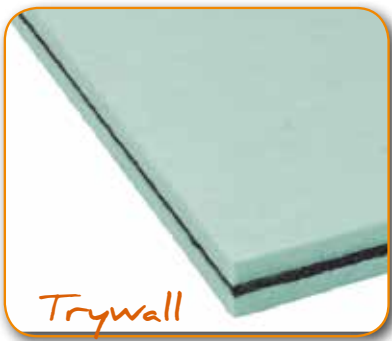

Trywall



Biwall

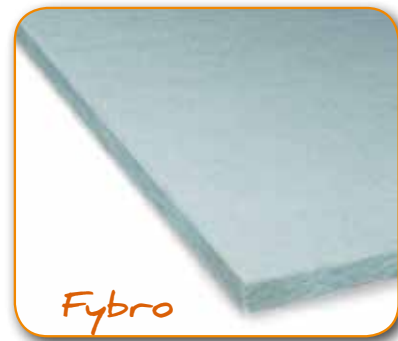

Fybro

Accessori - Accessories



Vite doppio filetto /
Double thread screw



Stucco da cartongesso &
nastro in rete /
Filling for plasterboard
& Mesh tape

CONTROSOFFITTO SOSPESO SUSPENDED CEILING

Incollare alle guide metalliche la striscia adesivizzata **Stywall S3A** e fissarle lungo il perimetro alla distanza prefissata dal soffitto

*Glue the adhesive strip **Stywall S3A** to the metal studs and fix them along the perimeter of the room at a fixed distance from the ceiling*



Tracciare e posare le staffe universali (vedi tabella). In caso di solaio in latero-cemento fissare le staffe sui travetti.

Mark and fix the universal bracket (see the table)



Carico P Load P (kg/m ²)	Distanza pendini - A (mm) Hangers distance	Distanza profili portanti - B (mm) Primary grid (metal studs) distance
15	900	1000
15 < P ≤ 30	750	1000
30 < P ≤ 50	600	750

Avvitare l'orditura metallica portante alla staffa universale

Fix to universal bracket the metal studs of primary grid





Trywall - Biwall - Fybro

Fissare alle guide lungo il perimetro l'orditura metallica portante

Fix the metal studs of primary grid along the perimeter channel



Inserire l'orditura secondaria all'interno della guida perimetrale

Insert the metal stud of secondary grid in the perimeter channel



Fissare con gli appositi ganci l'orditura metallica secondaria ai profili portanti

Fix the metal stud of secondary grid to the primary grid with the appropriate connector

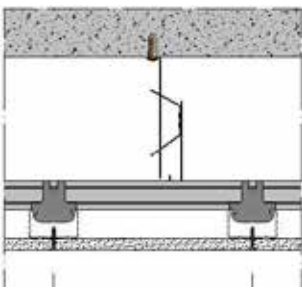

Tipo di rivestimento <i>Type of gypsumboard</i>	Interasse profili secondari <i>Secondary grid (metal studs) distance (mm)</i>		
Lastre spessore <i>Gypsumboard thickness</i> 12,5 mm, 15 mm , 18 mm, 2x12,5 mm		Posa trasversale <i>Cross application</i>	Posa longitudinale <i>Longitudinal application</i>
		500	400

Appoggiare sopra l'orditura i pannelli isolanti
*Place on top of the primary and secondary grid
the insulation panels*



Appoggiare la lastra di cartongesso ai profili metallici
Lean the gypsum board to the metal frame



Fissare le lastre di cartongesso con le viti
Fix the gypsum board by screwing



Applicare il nastro in rete nelle giunzioni
delle lastre. Stuccare le giunzioni
*Apply the plastic mesh tape in the gypsum
boards jointing lines and grouting*





FORO DI VENTILAZIONE
VENTILATION HOLE

Sylencer

Laterizio
Brick wall

Isolamento termico
Thermal insulation

Laterizio
Brick wall

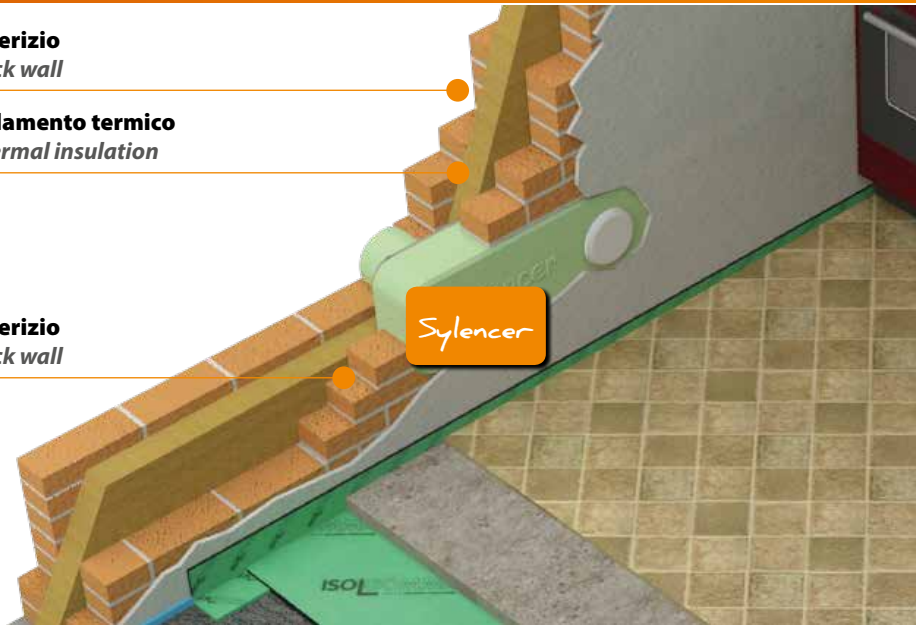

Isolamento facciate Facade insulation



Iniziare a relizzare la parete
Start to built the wall



Posare il **Sylencer** sul letto di malta
Lay the Sylencer on mortar



Realizzare la parete attorno al **Sylencer** e intonacare utilizzando la rete portaintonaco
Build the wall around the Sylencer and plaster onto the product with a plastic mesh



Tagliare o togliere il tappo del **Sylencer** e inserire la griglia di finitura
Cut or remove the cap and insert the grid in the hole of the Sylencer

SOTTOPARETE UNDERWALL

Stywall AD

Pavimento
Floor finishing

Massetto
Concrete screed

Alleggerito
Levelling screed

Laterizio
Brick wall

Solaio
Base floor



Stendere la striscia sottoparete. La striscia deve essere più larga della parete di almeno 2 cm per lato

Lay the under wall strip. The strip must be wider than the wall thickness of at least 2 cm per side



Realizzare la prima parete sopra la striscia sottoparete **Stywall** posandola su un letto di malta

*Over the **Stywall** lay down a plaster bed in order to start the wall built up*



FONDAZIONI SUPERFICIALI
STRUCTURAL BEARINGS

Megamat

Terreno
Ground

Plinto di fondazione
Foundation plinth

Trave di fondazione
Foundation beam

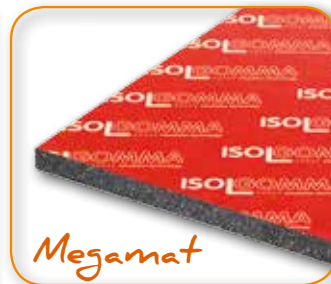

Megamat

Accessori
- Accessories



Stik

Anti-vibration
Antivibrante



Realizzare la base dell'edificio
Build the base of the foundation



Posare il materassino Megamat alle base dei plinti e delle travi di fondazione
Lay down the Megamat panel in the structural column and/or wall in the bearing palce

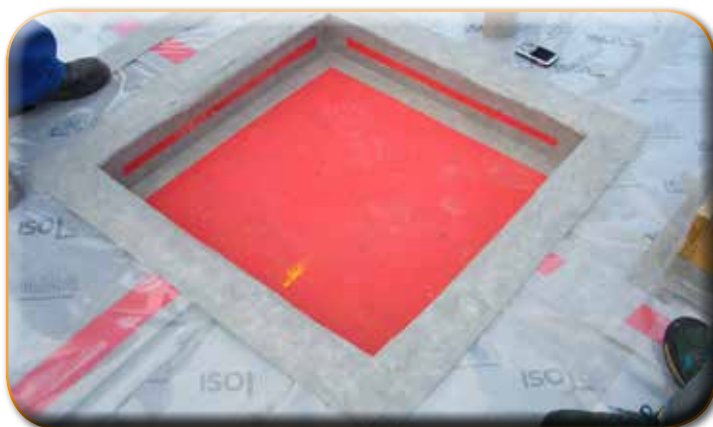

Sigillare le giunzioni tra i pannelli con Stik
Seal the joints of the panel with the Stik tape



Realizzare i plinti e le travi di fondazione
Build the foundation plinth or beam

FONDAZIONE A PLATEA GROUND SLAB FOUNDATION

Terreno
Ground

Plinto di fondazione
Foundation plinth

Trave di fondazione
Foundation beam

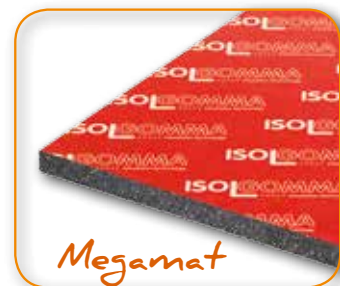

Accessori
- Accessories



Stik

Costruire la fossa di contenimento della
fondazione

*Dig the foundation pit and construct the pit
substrate*



Posare i pannelli di **Megamat** avendo cura
di accostarli senza lasciare fessure o cavità
lungo i bordi di giunzione

*Lay **Megamat** panels paying attention to not
to leave any gaps between adjacent panels*





Megamat

Sigillare le giunzioni orizzontali accuratamente con il nastro adesivo **Stik**

*Seal the joints carefully using **Stik** adhesive tape*



Incollare i pannelli sui fianchi della fossa con colle poliuretaniche avendo cura di accostarli con precisione e quindi di sigillare le giunzioni con nastro **Stik**

*Glue the panels to the pit walls using polyurethane binder. Then seal the joints carefully using **Stik** adhesive tape*



Sigillare le giunzioni verticali accuratamente con il nastro adesivo **Stik**

*Seal the wall panel joints with **Stik** tape*





Realizzare la fondazione in calcestruzzo direttamente sulla fossa rivestita

Foundation casting can now be done directly into the insulated pit

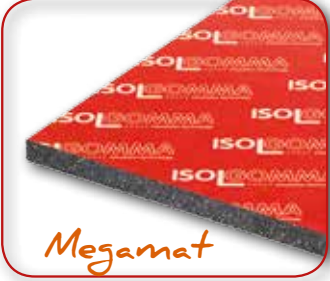

UNITÀ TRATTAMENTO ARIA HVAC

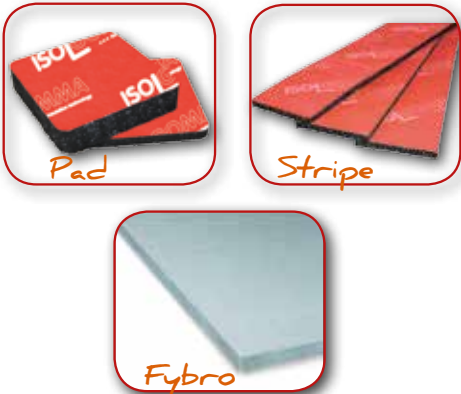
<p>SENZA MASSETTO</p> <p>WITHOUT FLOATING SCREED</p>	 <p>Pad Stripe</p>	<p>Intervallo di carico ottimale per appoggio <i>Optimal load range per bearing</i></p> <p>Pad: 200 kg ÷ 2000 kg Stripe: 800 kg ÷ 5000 kg</p>
<p>CON MASSETTO</p> <p>WITH FLOATING SCREED</p>	 <p>Megamat</p>	<p>Carico ottimale sul prodotto: <i>Optimal load on the product:</i></p> <p>0.04 N/mm² ÷ 0.35 N/mm²</p> <p>Deflessione in funzione del carico: <i>Deflection under load:</i></p> <p>5 % ÷ 30 %</p>
	 <p>Grei</p>	<p>Installabile fino a 4 strati sovrapposti Carico ottimale sul prodotto fino a 0.04 N/mm² Deflessione fino a 40 %, in funzione del carico Profilo di contenimento obbligatorio</p> <p><i>Installation up to 4 layers Optimal load range on the product up to 0.04 N/mm² Deflection under load up to 40 %, depending on load A protection on side is strongly suggested</i></p>
	 <p>Pad Stripe Fybro</p>	<p>Carico ottimale su intera superficie fino a 0.04 N/mm² (carico superiore sui singoli appoggi) Flessibilità di progettazione: la disposizione degli appoggi Pad e Stripe può essere progettata in funzione del singolo macchinario da isolare</p> <p><i>Optimal load on the whole surface up to 0.04 N/mm² (load can be higher on the pads) Flexible design: the layout of the bearings Pad / Stripe can be designed depending on the characteristics of the machine</i></p>



Megamat

UTA
HVAC

Solaio
Concrete base

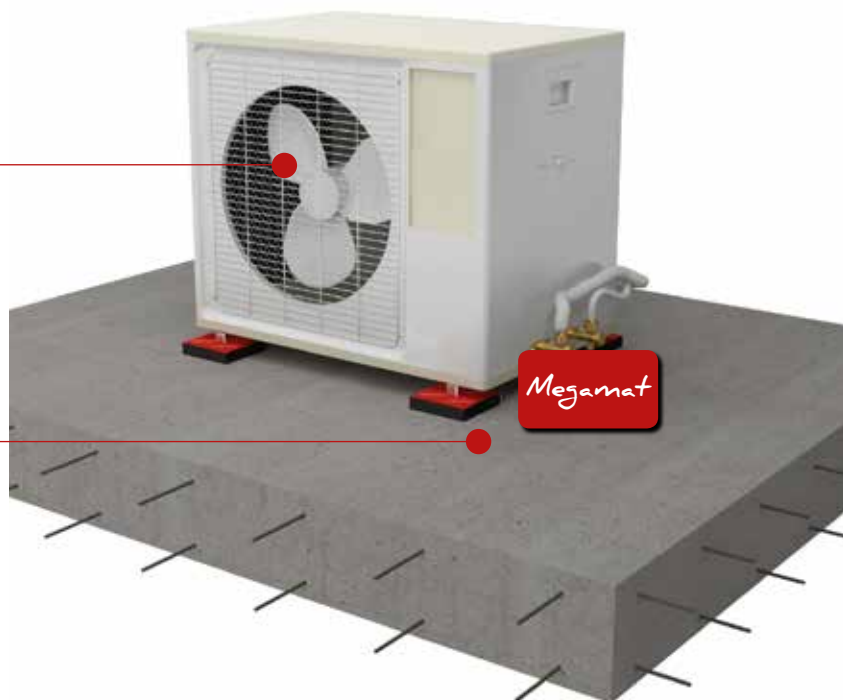

Pad

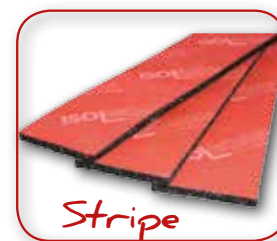

Stripe

Accessori
- Accessories



Stik

Appoggiare o incollare con colle poliuretatiche i pannelli **Megamat** in piastre o strisce sulla superficie da isolare

*Lay down on the floor the strip or the pads of **Megamat** and glue them on floor with the polyurethanes glues*



Appoggiare la macchina da isolare direttamente sulle piastre o strisce

Place the machine over the strip or pads



UNITÀ TRATTAMENTO ARIA HVAC

UTA
HVAC

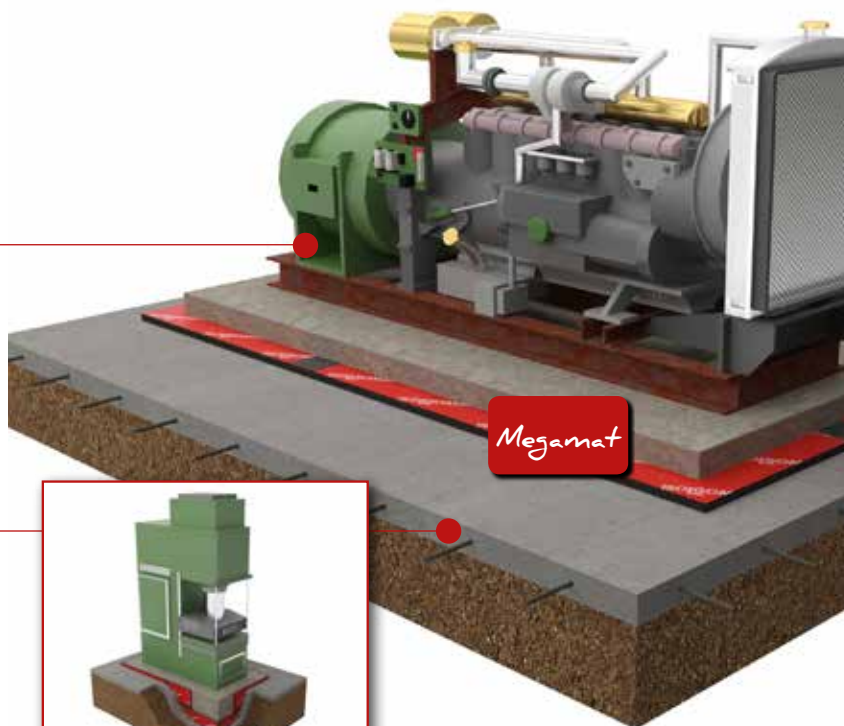

Solaio
Concrete base

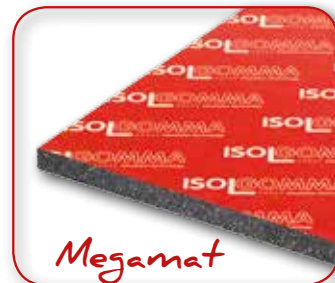

Megamat

Accessori
- Accessories



Stik

Posare il materassino **Megamat** alla base

*Lay down on the floor the **Megamat** panel*



Sigillare le giunzioni orizzontali accuratamente con nastro adesivo **Stik**

*Seal the joints carefully using **Stik** adhesive tape*





Megamat

Incollare il materassino sulle pareti verticali e sigillare le giunzioni con il nastro **Stik**

*Glue the panel on the vertical walls of the foundation and seal the joints with the **Stik** tape*



Predisporre l'armatura nel cassero del basamento

Place the steel mesh to prepare the reinforced concrete base



Realizzare il basamento

Build the concrete base



Posare l'unità trattamento aria

Place the machine on the concrete base



UNITÀ TRATTAMENTO ARIA HVAC

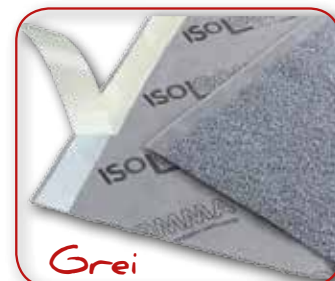
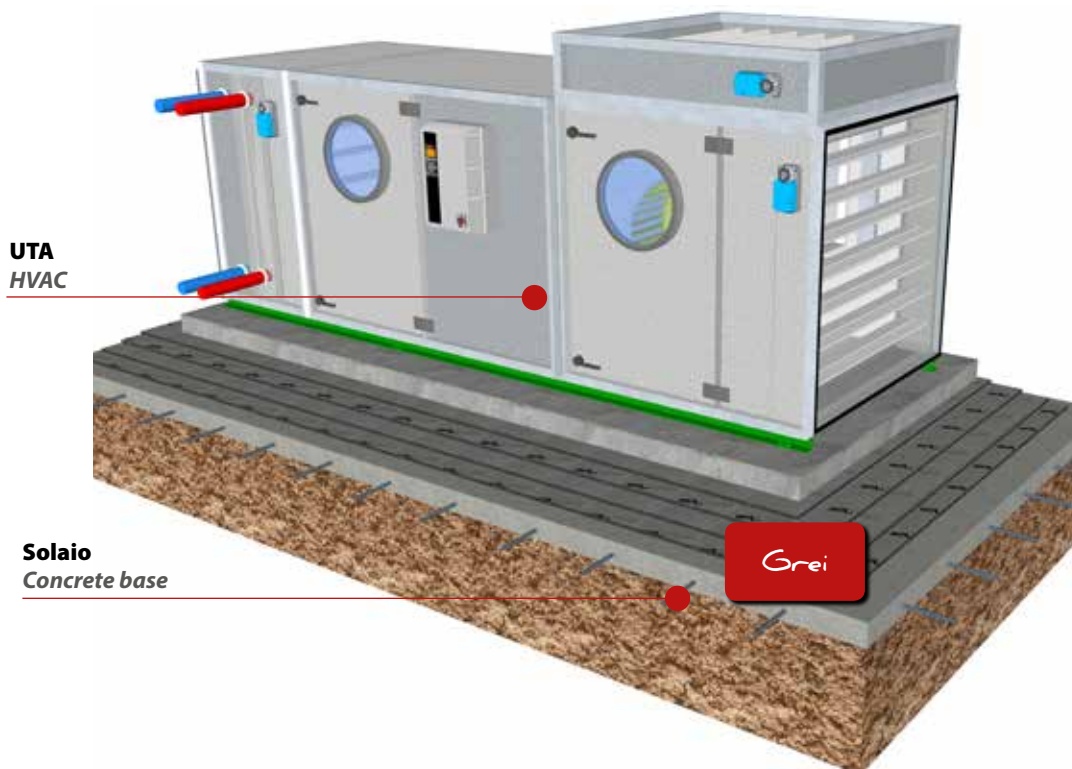

Accessori - Accessories



Stik

Realizzare il cordolo di contenimento (in cemento oppure mediante profili metallici ad L)

Build the containment pit (concrete or steel L-shaped profile)



Incollare la striscia perimetrale **Profyle Flat** sulla superficie verticale del cordolo di contenimento, rimuovendo la pellicola adesiva

*Apply the edging strip **Profyle Flat** on the vertical surface of the containment pit, after removing the adhesive film*





Grei

Stendere l'isolante acustico **Grei** con i granuli di gomma rivolti verso il basso in quattro strati

*Install the insulation mat **Grei** on the floor surface with the rubber granules facing down in four layers*



Applicare uno telo protettivo prima della realizzazione del massetto

Protect the surface of the resilient layer with a waterproof film, before building the slab



Predisporre l'armatura e realizzare il basamento flottante

Place the reinforcement steel meshes and build the floating slab

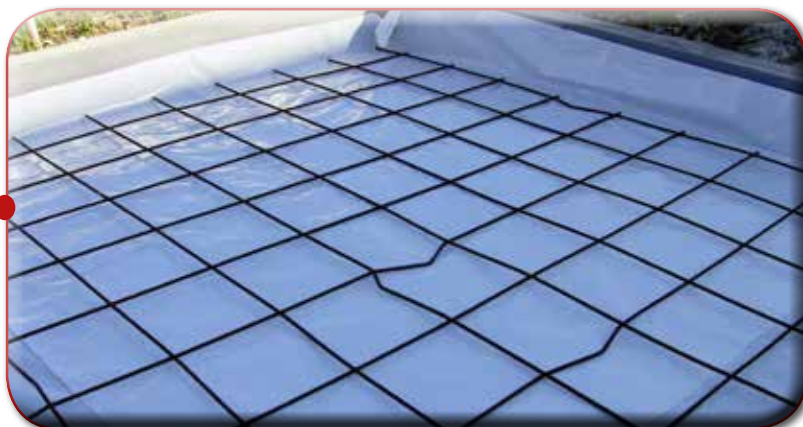

Installare l'unità trattamento aria sul basamento flottante come di consueto

Place the HVAC on the concrete floating slab as usual



UNITÀ TRATTAMENTO ARIA HVAC

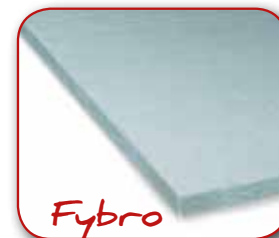

Accessori - Accessories



Stik

Realizzare il cordolo di contenimento (in cemento oppure mediante profili metallici ad L)

Build the containment pit (concrete or steel L-shaped profile)



Incollare i pannelli **Megamat** sulle superfici verticali del cordolo, avendo cura di accostarli con precisione

*Glue the **Megamat** panels on the vertical surface of the containment pit, without leaving any gaps between two adjacent panels*





Megamat

Posare **Pad/Stripe** e i pannelli di **Fybro** secondo progetto

*Place the **Pad/Stripe** bearings and the **Fybro** panel, according to the designed layout*

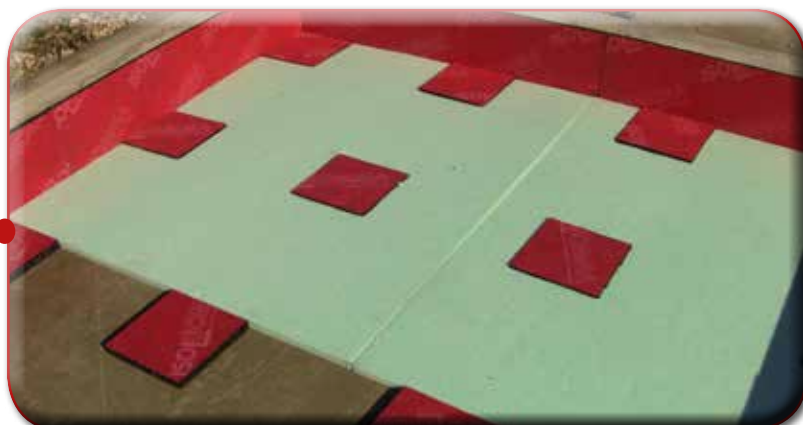

Sigillare le giunzioni verticali con nastro adesivo **Stik** (ed eventuali fessure tra i componenti orizzontali, se superiori ai 2 mm) e applicare un telo protettivo prima della realizzazione del basamento flottante

*Seal the vertical junctions between adjacent panels with **Stik** tape (and any gaps between the components placed on the floor, if higher than 2 mm) and apply a waterproof film before building the floating slab*



Predisporre l'armatura e realizzare il basamento flottante

Place the reinforcement steel meshes and build the floating slab



Installare l'unità trattamento aria sul basamento flottante come di consueto

Place the HVAC on the concrete floating slab as usual





TUBAZIONI PIPES

Stywall



Laterizio
Brick wall

Isolamento termico
Thermal insulation

Laterizio
Brick wall



Stywall S3A



Assicurarsi che le superfici delle tubazioni siano prive di residui. Rimuovere il film adesivo e incollare **Stywall A** attorno alle tubazioni

*Check that the pipes surfaces are free of any residue. Remove the adhesive film and glue **Stywall A** around pipes*



Inserire il tubo nell'apposito alloggiamento

Insert the pipe into the bracket



Proseguire con l'applicazione del prodotto attorno alle tubazioni

Continue the application of the product around pipes

AVVERTENZE

Le indicazioni e le prescrizioni sopra riportate pur corrispondendo alla nostra migliore esperienza, sono da ritenersi in ogni caso, puramente indicative e dovranno essere confermate da esaurienti applicazioni pratiche; pertanto, prima di adoperare il prodotto, chi intenda farne uso è tenuto a stabilire se esso sia o meno adatto all'impiego previsto e, comunque, si assume ogni responsabilità che possa derivare dal suo uso.

MANUALE PER PROFESSIONISTI

Fare sempre riferimento all'ultima versione aggiornata delle schede tecniche dei prodotti contenuti in questo manuale, disponibili sul sito www.isolgomma.com.

WARNING

While the indications and guidelines contained in this manual installation to the company's knowledge and wide experience, they must be considered, under all circumstances, merely as an indication and subject to confirmation only after long-term, practical applications.

Therefore, anybody who undertakes to use this product, must ensure beforehand that it is suitable for the intended application and, in all cases, the user is to be held responsible for any consequences deriving from its use.

MANUAL FOR PROFESSIONAL USE

Please refer to the current version of the Technical Data Sheets of the products contained in this manual, available from our web site www.isolgomma.com.

Acoustic Isolation & Vibration Control

ISOLGOMMA

★★★★★

Isolgomma Srl

36020 Albettono (Vicenza) Italy - via dell'Artigianato, 24

tel. +39 0444 790781 - fax +39 0444 790784

info@isolgomma.com - www.isolgomma.com



Dystrybutor / Distributor